

ALE

ALE - 11 - Ed 11 - May 2021

This is a general specification leaflet; for specific applications not covered herein, contact Suntec.

The SUNTEC **ALE** oil pump incorporates a blocking solenoid valve fitted with a built-in return valve ensuring an in-line cut-off function and a nozzle line pressure relief. The integration of the return valve into the solenoid valve means that the ALE pump performance and dimensions are identical to the AL pump.

COMPATIBILITY

- Domestic oil, HVO, B30 (biofuel blend with the addition of 30% FAME, as defined in DIN SPEC 51603-6), kerosene.
- One or two-pipe system

PUMP OPERATING PRINCIPLE

The gear set draws oil from the tank through the built-in filter and transfers it to the nozzle line via the cut-off solenoid valve. A pressure regulating valve is used to dump all oil which is not required at the nozzle.

In two-pipe operation, the by-pass plug must be fitted in the return port, which ensures that the oil by-passed by the regulating valve is returned to the tank and the suction line flow is equal to the gear set capacity.

In one-pipe operation, the oil which does not go through the nozzle line is returned directly to the gear inlet and the suction line flow is equal to the nozzle flow. In that case, the by-pass plug must be removed from the return port, and the return port sealed by steel plug and washer.

Bleed

Bleeding in two-pipe operation is automatic : it is assured by a bleed flat on the piston.

In one-pipe operation, the plug of a pressure gauge port must be loosened until the air is evacuated from the system.

Cut-off

The solenoid valve of the ALE pump is of the "normally closed" type and is situated in the nozzle line. This design ensures extremely fast response and the switching can be selected according to the burner operating sequence and is independent of motor speed.

When the solenoid is non-activated, the valve is closed and all oil pressurized by the gear set passes through the regulator to the suction or return line, depending upon pipe arrangement. As soon as the solenoid is activated, oil passes to the nozzle line at the pressure set by the pressure regulating valve.

Nozzle line pressure relief

The nozzle line pressure relief function operates only when the installation is fitted with a nozzle incorporating a cut-off function which opens at 4 bars or above. Any subsequent expansion of the oil due to residual heat from the preheater or the boiler is discharged through the relief valve in the pump which opens at a lower pressure than the nozzle opening pressure.

Note : For a boosted pump, the overpressure applies to the safety shut-off device and the relief valve.

PUMP IDENTIFICATION

(Not all model combinations are available
Consult your Suntec representative)

ALE : blocking solenoid valve with in-line cut-off function and nozzle line pressure relief device
V : B30 applications

Gear set capacity (see pump capacity curves)

Shaft rotation and nozzle location (seen from shaft end)

A : clockwise rotation/ right hand nozzle.
B : clockwise rotation/ left hand nozzle.
C : anti clockwise rotation/ left hand nozzle.
D : anti clockwise rotation/ right hand nozzle.

K : Kerosene applications

Pump series 3 : hub Ø 32 mm

Model number

ALE V 35 C K 9 3 xx 6 P 07 00

Revision number

Installation

P : by-pass plug inserted in return port for two-pipe operation
M : without by-pass plug, return plugged, for one-pipe operation

Solenoid valve voltage

05/07 : 220-240 V AC - 50/60 Hz
06 : 110-120 V AC - 50/60 Hz
02 : 24V AC - 50/60 Hz

Connector cable length

00 : no cable
35 : 35 cm cable - 45 : 45 cm cable
60 : 60 cm cable - 10 : 1 m cable

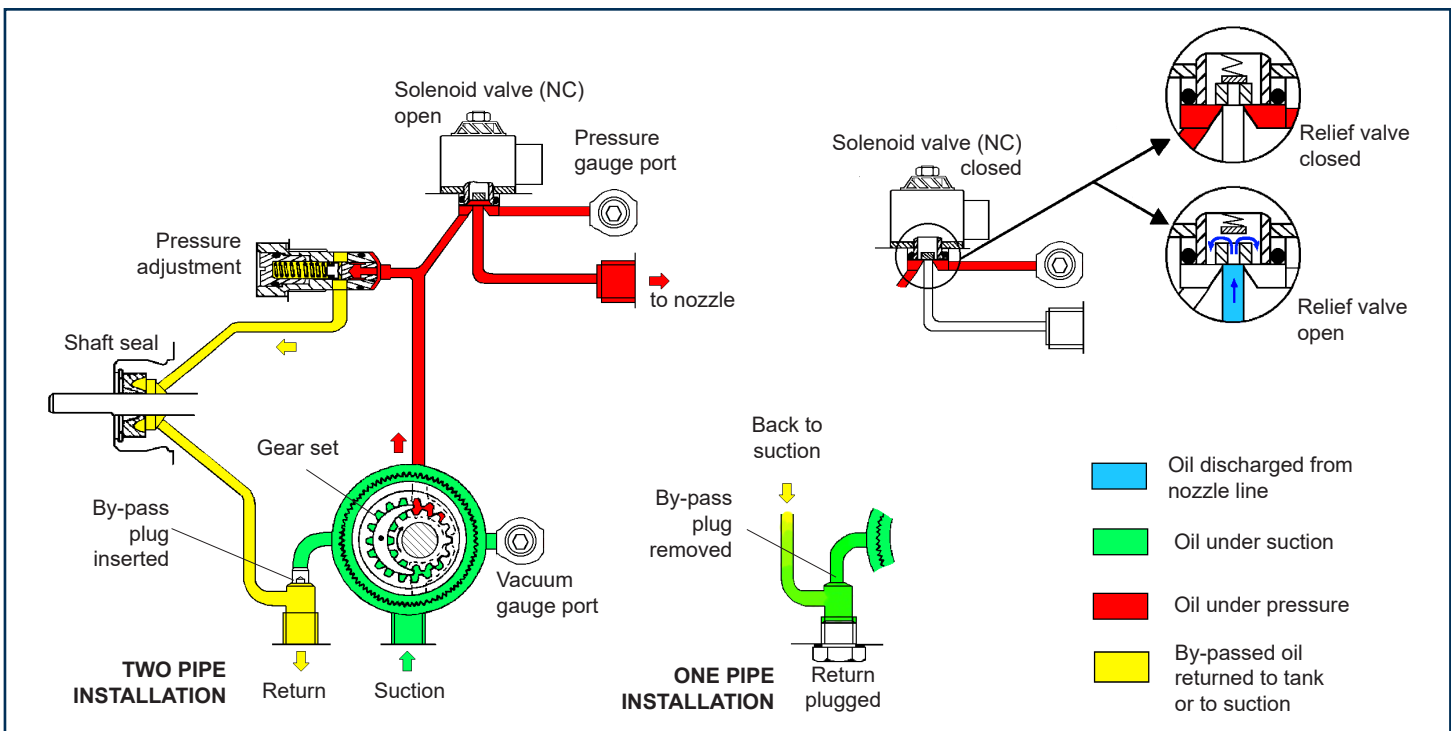

TECHNICAL DATA

General

Mounting	Hub mounting according to EN 225	
Connection threads	cylindrical according to ISO 228/1	
Inlet and return	G 1/4 (with facilities for conical sealing on revision 6 models)	
Nozzle outlet	G 1/8	
Pressure gauge port	G 1/8	
Vacuum gauge port	G 1/8	
Valve function	Pressure regulation	
Strainer	open area : 6 cm ² - opening size : 150 µm	
Shaft	Ø 8 mm according to EN 225	
By-pass plug	inserted in return port for two-pipe system ; to be removed with a 4 mm Allen key for one pipe system.	
Weight	1,1 kg	

Hydraulic Data

Gear size	Nozzle pressure range*	Factory setting
35/55	4 - 18 or 7-25 bars @ 5 cSt	9 or 12 bars
35K/55K	8 - 15 bars @ 1,8 cSt	9 bars

*other ranges available on request, refer to the specified range of the particular fuel unit.

Viscosity range	1,25 - 12 mm ² /s (cSt) for ALE 35K/55K 2 - 12 mm ² /s (cSt) for ALE 35/55	
Oil temperature	0 - 60°C in the pump	
Inlet pressure	2 bars max.	
Return pressure	2 bars max.	
Suction height	0,45 bars max. vacuum to prevent air separation from oil.	
Rated speed	3600 rpm max.	
Torque (@ 45 rpm)	0,10 N.m	

Solenoid valve characteristics

Voltage	220 -240 or 110-120 or 24 V; 50/60 Hz
Consumption	9 W max.
Coil Code*	Ambient temperature
06/02/05	0 - 60 °C
07	0 - 80 °C

*Refer to "Pump identification - solenoid coil voltage".

Maximum pressure	25 bars
Relief valve opening pressure	3,5 bars max. (without booster)
Certified	TÜV Nr. stamped on pump cover
Protection class	IP 54 according to EN 60529, when used with SUNTEC connector cable.

Pump capacity

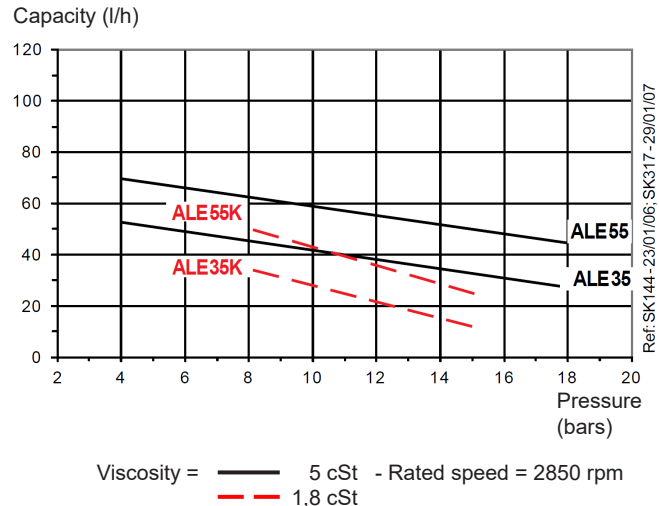

Data shown take into account a wear margin.
Do not oversize the pump when selecting the gear capacity.

Power consumption

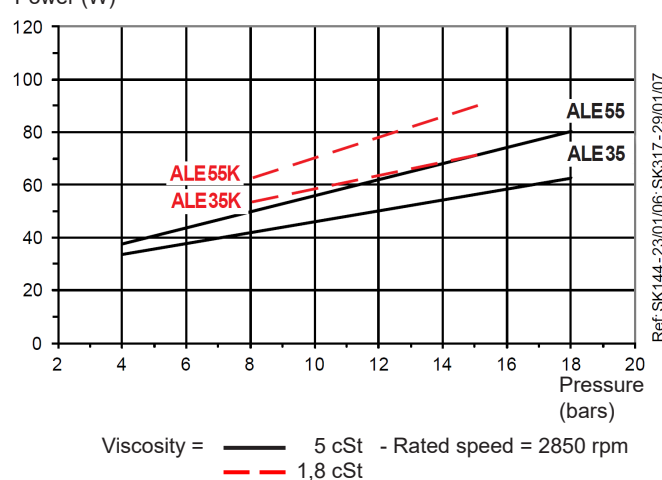

PUMP DIMENSIONS

Examples show "C" rotation and nozzle outlet.

Pumps revision 6

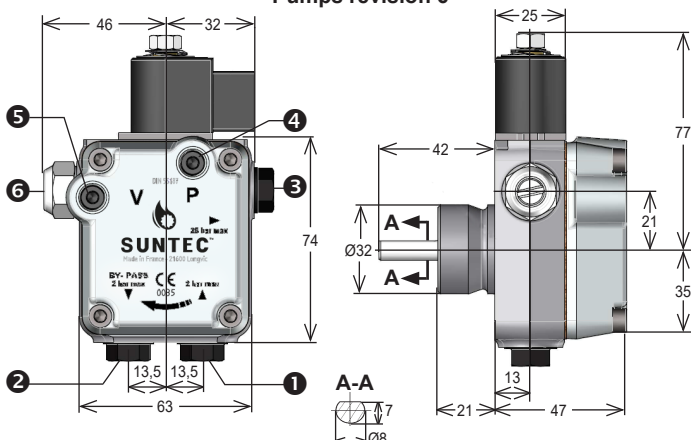

Inlet ① and Return ② with direct sealing for revision 6 models (sealing with washers can also be used)

Pumps revision 4

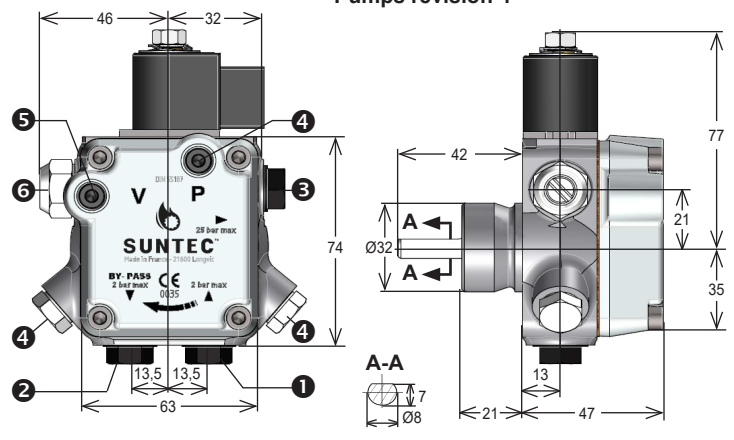

- ① Suction
- ② Return and internal by-pass plug
- ③ Nozzle outlet
- ④ Pressure gauge port
- ⑤ Vacuum gauge port
- ⑥ Pressure adjustment