

This is a general specification leaflet ; for specific applications not covered herein, contact Suntec.

The SUNTEC **TA** oil pump is specially designed for industrial heating applications using light or heavy oils. It is fitted with a preheater location to render cold starting easier.

COMPATIBILITY

- Heavy oil, light oil, B100.
- One or two-pipe system.

PUMP OPERATING PRINCIPLE

The gear set draws oil from the tank and transfers it to the valve regulating the oil pressure to the nozzle line. All oil which does not go through the nozzle line will be dumped through the valve back to the return line in two pipe installation or, if it is a one-pipe installation, back to the gear-set.

Bleed

The plug of the pressure gauge port must be loosened until the air is evacuated from the system.

Note

All TA models are delivered for two-pipe system (by-pass plug fitted in vacuum gauge port).

For one-pipe system, the by-pass plug must be removed and the return port sealed by steel plug and washer.

PREHEATING FACILITY

Care should be taken to avoid starting pump with high viscosity cold oil leading to pump and coupling damage. For this reason, the TA pump body includes a cavity to accept an electric preheater. This cavity has been located to give maximum heat transfer from the heater to the oil in the pump without direct contact between the heater cartridge and the oil.

Heaters should be connected for a period of time prior to starting the pump. When the right temperature is reached, they can be switched off or left permanently switched on to maintain fluid oil in the pump during the periodic burner shut-downs.

The oil supply, pipes and filters must be separately heated.

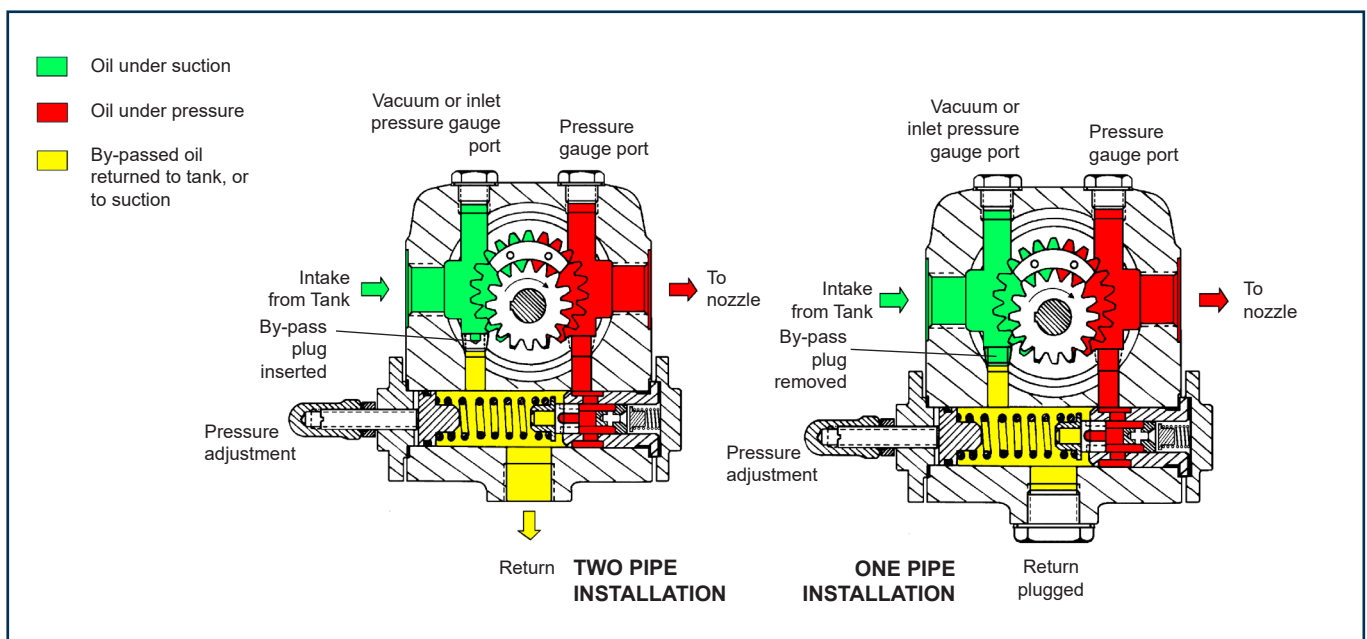
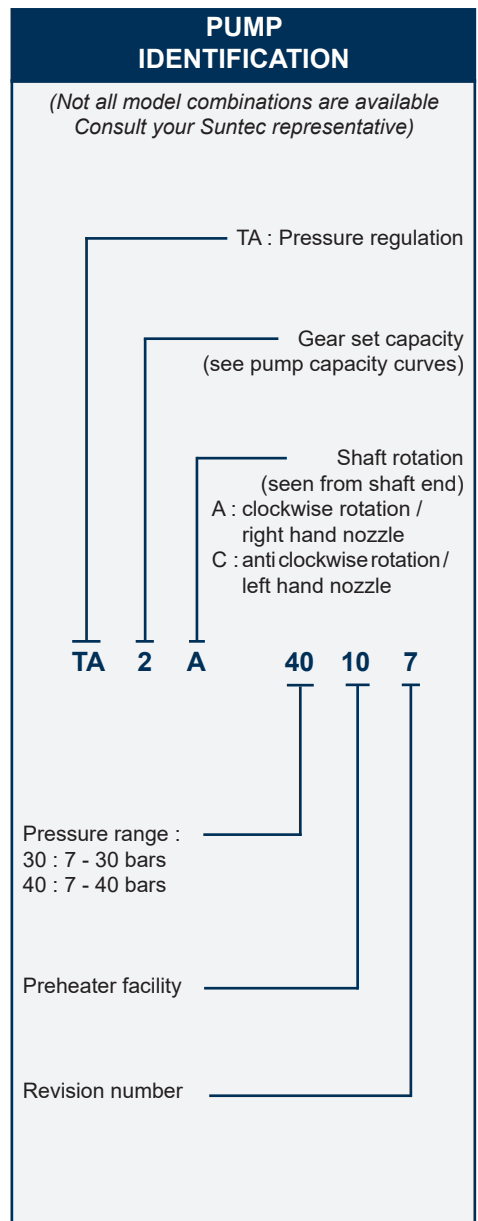

TECHNICAL DATA

General

Mounting	Flange mounting
Connection threads	Cylindrical according to ISO 228/1
Inlet and return	G 1/2
Nozzle outlet	G 1/2
Pressure gauge port	G 1/4
Vacuum gauge port	G 1/4
Shaft	Ø 12 mm
By-pass plug	Inserted in vacuum gauge port for 2 pipe system; to be removed with a 3/16" Allen key for 1 pipe system
Weight	5,4 kg (TA2) - 5,7 kg (TA3) 6 kg (TA4) - 6,4 kg (TA5)

Hydraulic data

Nozzle pressure ranges	30 : 7 - 30 bars 40 : 7 - 40 bars
Delivery pressure setting	30 bars
Operating viscosity	2 - 75 mm ² /s (cSt) <i>(Higher viscosity oil can be used by feeding the pump and by heating the oil to lower its viscosity under 75 cSt. For kerosene applications, contact SUNTEC).</i>
Oil temperature	0 - 150°C in the pump
Inlet pressure	light oil : 0,45 bars max. vacuum to prevent air separation from oil heavy oil : 5 bars max.
Return pressure	light oil : 5 bars max. heavy oil : 5 bars max.
Rated speed	3600 rpm max.
Torque (@ 40 rpm)	0,3 N.m

Choice of heater

Cartridge	Ø 12 mm
Fitting	according to EN 50262
Rating	80-100 W

Pump capacity

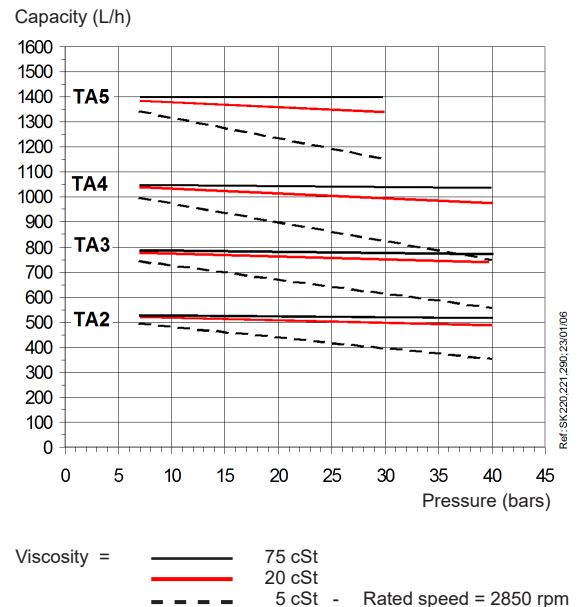

Data shown are for new pumps, with no allowance for wear.

Power consumption

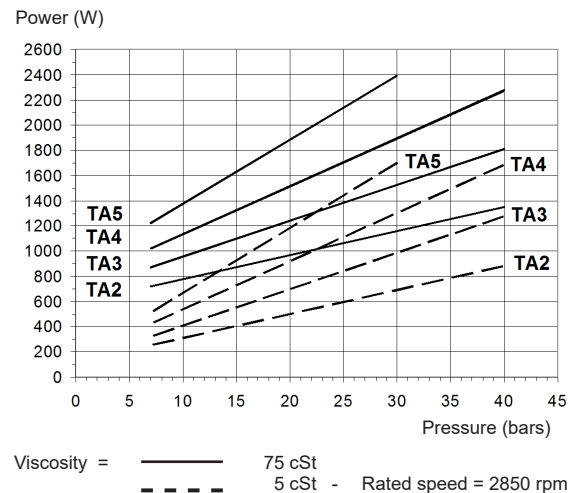

Data shown are for new pumps, with no allowance for wear.

PUMP DIMENSIONS (in mm)

Example shows pump with "C" rotation and serial number³ 500 000. - Reverse all pump connections for "A" rotation.

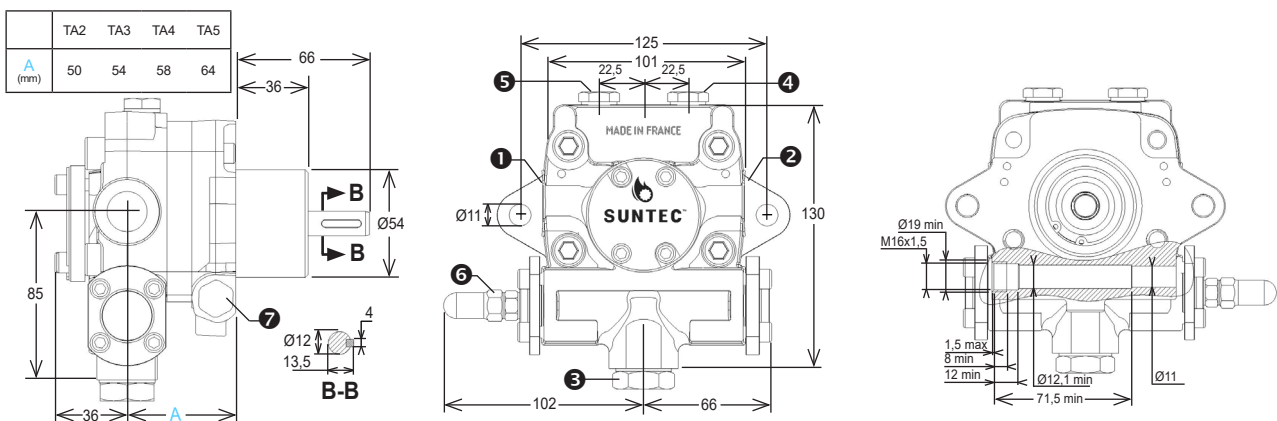

- ① Suction
- ② Nozzle outlet
- ③ Return
- ④ Pressure gauge port
- ⑤ Vacuum or inlet pressure gauge port and internal by-pass plug
- ⑥ Pressure adjustment
- ⑦ Preheater cavity