

This is a general specification leaflet ; for specific applications not covered herein, contact Suntec.

The SUNTEC TV valve is a pressure regulating valve.

APPLICATIONS

- Heavy oil, light oil, B100.
- Capacity up to 5000 l/h.
- May be used with the SUNTEC T pump.

VALVE OPERATING PRINCIPLE

The pressure of the nozzle line is adjusted with the adjusting screw of the TV valve. The oil in excess to nozzle requirement is dumped to the return.

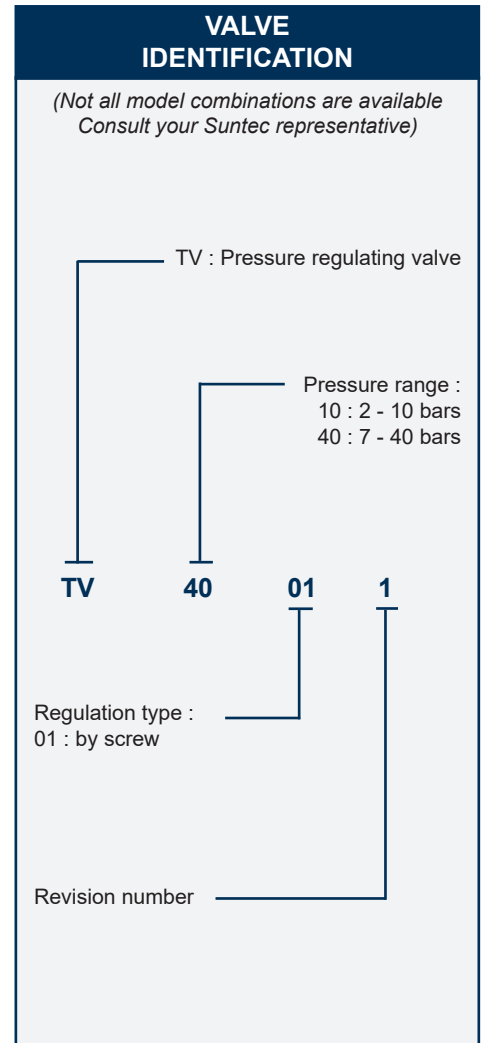
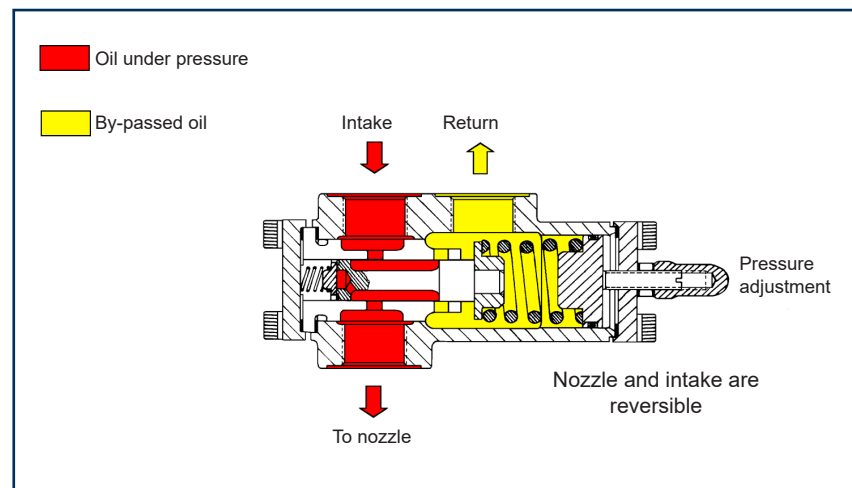

INSTALLATION

Two pipe system : oil in excess is returned to tank.

One pipe system : oil in excess is returned to pump suction.

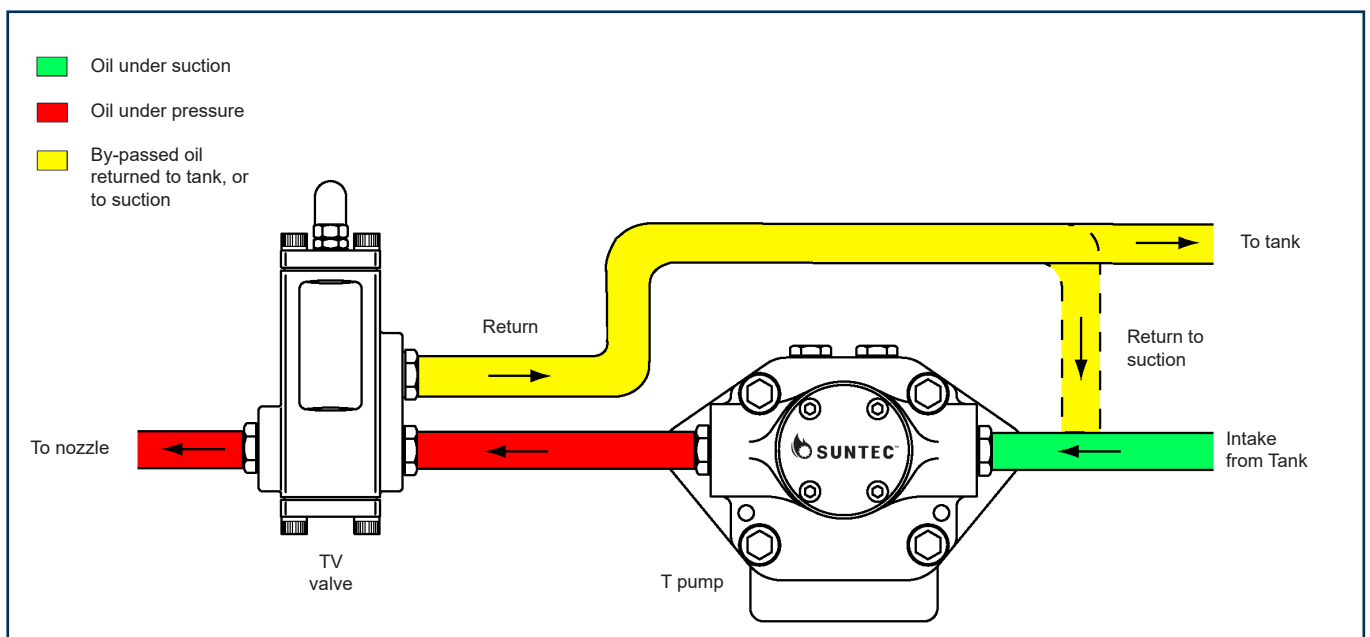

TECHNICAL DATA

General

Connection threads	Cylindrical according to ISO 228/1
Inlet	G 3/4
Nozzle outlet	G 3/4
Return	G 3/4
Weight	3 kg

Hydraulic data

Pressure ranges	10 : 2 - 10 bars (delivery pressure setting : 7 bars)
	40 : 7 - 40 bars (delivery pressure setting : 20 bars)
Operating viscosity	3 - 75 mm ² /s (cSt) <i>(Higher viscosity oil can be used by heating the oil to lower its viscosity under 75 cSt. For kerosene applications, contact SUNTEC)</i>
Oil temperature	0 - 150°C max. in the valve.

MOUNTING POSITION

TV valve may be mounted in any position.

PRESSURE ADJUSTMENT

Remove cap-nut ❶ and washer ❷, unscrew lock-nut ❹.
To increase pressure, turn adjusting screw ❸ clockwise.
To decrease the pressure, turn screw anticlockwise.
Block lock-nut ❹, refasten washer ❷ and cap-nut ❶.

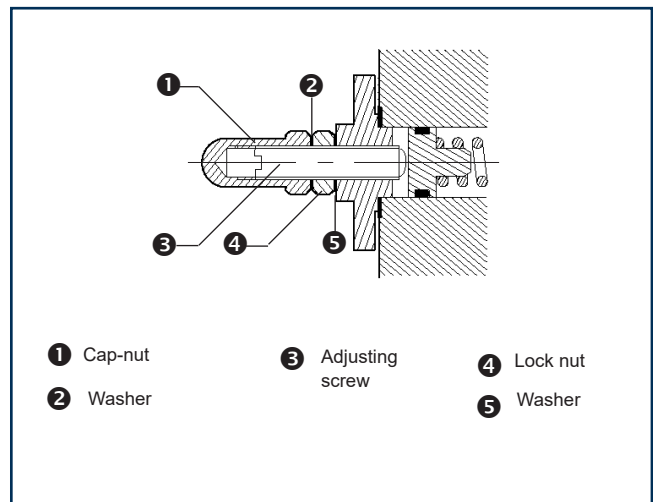

DIMENSIONS (in mm)

